

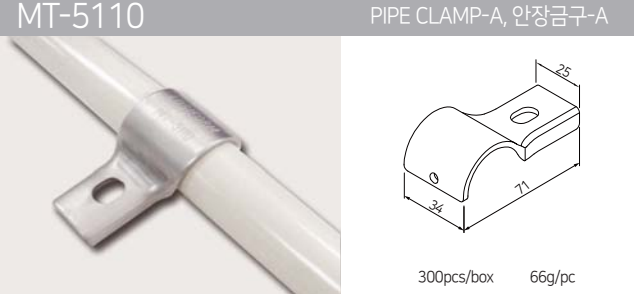

ACCESSORIES

MT-5110 PIPE CLAMP-A, 안장금구-A



300pcs/box 66g/pc

MT-5111 PIPE CLAMP-B, 안장금구-B



400pcs/box 20g/pc

MT-5112 PIPE CLAMP-C, 안장금구-C

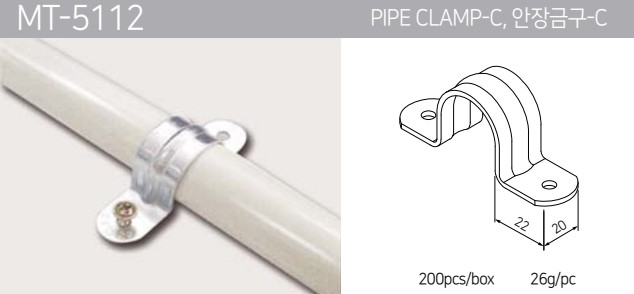

200pcs/box 26g/pc

MT-5113 BOARD FIXING-A, 판지고정금구-A

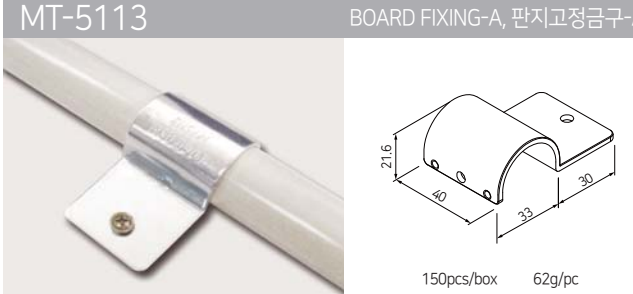

150pcs/box 62g/pc

MT-5114 BOARD FIXING-B, 판지고정금구-B

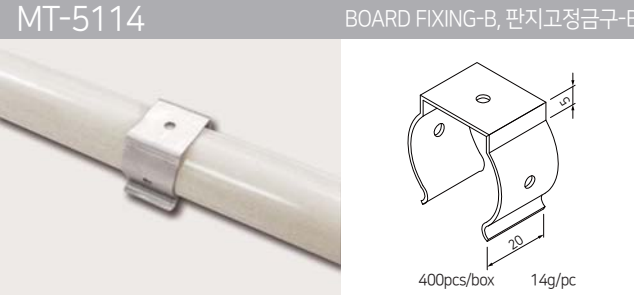

400pcs/box 14g/pc

MT-5120 PIPE HANGER 파이프걸이



1,000pcs/box 8g/pc

MT-5123 PIPE CONNECTOR 파이프연결금구

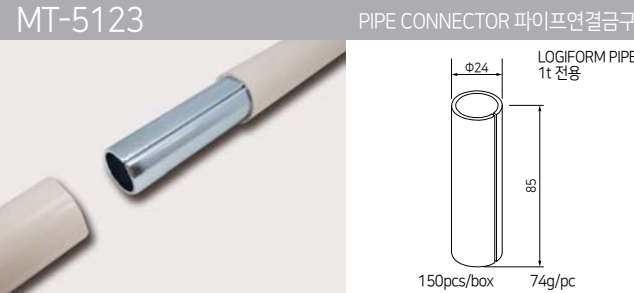

150pcs/box 74g/pc

MT-5125 BAND HANGER 밴드걸이



150pcs/box 48g/pc

MT-5126 LOCK MOUNT 로크금구

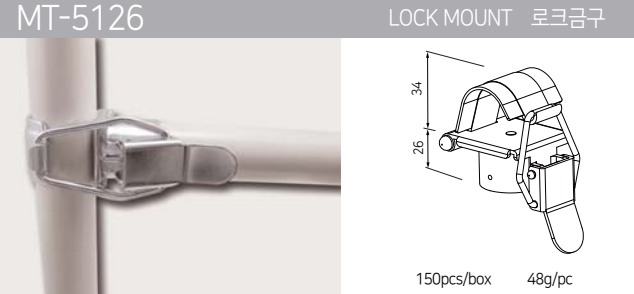

150pcs/box 48g/pc

MT-5127 HANGER U-TYPE, U형거

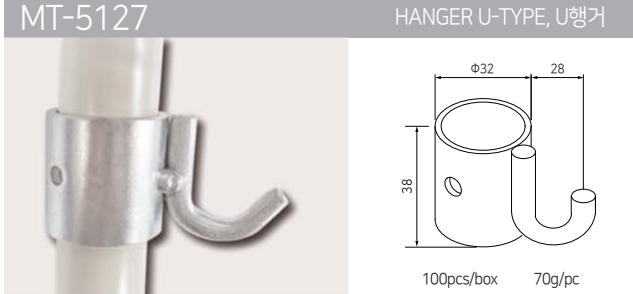

100pcs/box 70g/pc

ACCESSORIES

MT-5109 CASTER STRAP 캐스터지금구

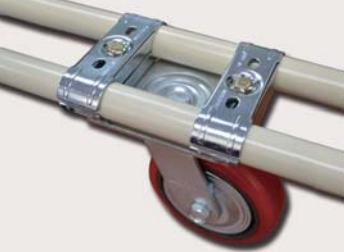
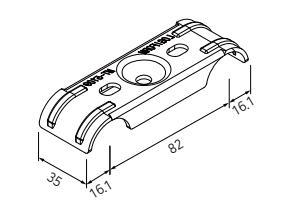
150pcs/box 95.5g/pc

MT-5109W CASTER STRAP-W, 캐스터지금구-W

120pcs/box 121g/pc

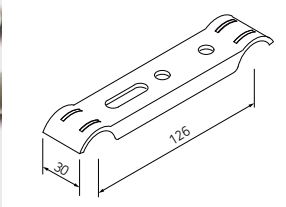
MT-5138L CORNER PLATE-L, 손잡이보강금구-좌

20pcs/box 988g/pc

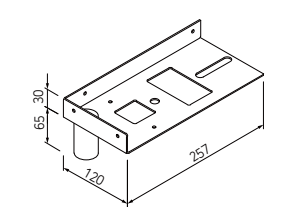
MT-5138R CORNER PLATE-R, 손잡이보강금구-우

20pcs/box 988g/pc

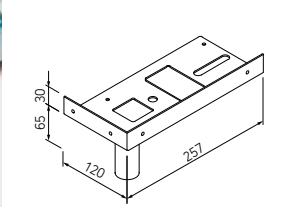
MT-5139L CORNER PLATE-L, 캐스터 코너 금구-좌

12pcs/box 1,268g/pc

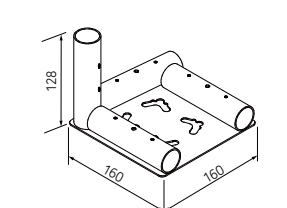
MT-5139R CORNER PLATE-R, 캐스터 코너 금구-우

12pcs/box 1,268g/pc

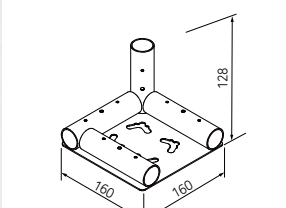
MT-5116 BOARD BRACKET-A, 판지고정코너금구-A

50pcs/box 110g/pc

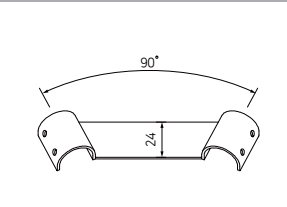
MT-5117 BOARD BRACKET-B, 판지고정코너금구-B

50pcs/box 72g/pc

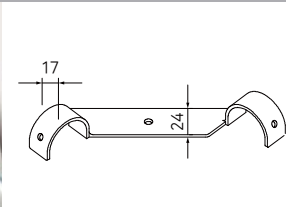
MT-5118 CORNER GUARD 코너금구

30pcs/box 72g/pc

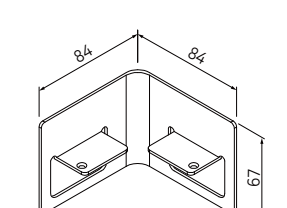
CG-0150BK - CORNER GUIDE

DOLLY 달리대차

METAL JOINT (HJ-1)

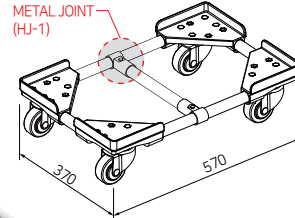
기본사양(standard) : 370 * 570
 ※ 기타 사이즈 : 주문 사양 제작
 (Size variation is available upon request)
DL-3757

Corner Guard for DOLLY
CG-0150BK
 (40pcs/box, 184.8g/pc)

ACCESSORIES

ACCESSORIES

MT-5130A HANDLE FIXING-A, 손잡이 고정금구-A

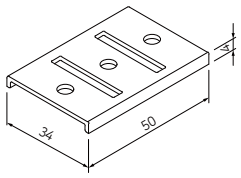
600pcs/box 22g/pc

MT-5130B HANDLE FIXING-B, 손잡이 고정금구-B

600pcs/box 22g/pc

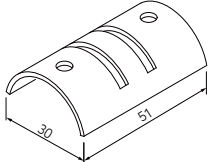
※근은 별도 판매

WG-0230 WIRE GUIDE



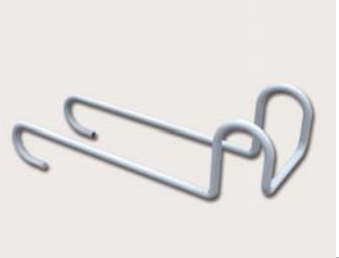
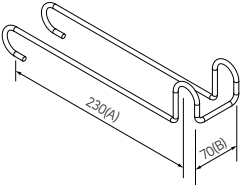

CODE	A	B
WG-0230 190g/pc	230	
WG-0330 240g/pc	330	70
WG-0430 280g/pc	430	

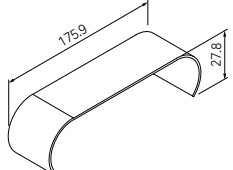

MIDDLE STOPPERS

MS-4018SV 40" MIDDLE STOPPER

300pcs/box 60g/pc

MS-7318SV 73" MIDDLE STOPPER

100pcs/box 126g/pc

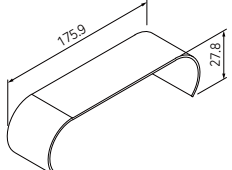
BOX STOPPERS

MT-5320 BOX STOPPER-A

80pcs/box 264g/pc

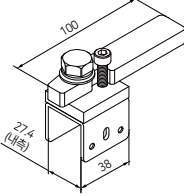
MT-5321 BOX STOPPER-B

20pcs/box 355g/pc

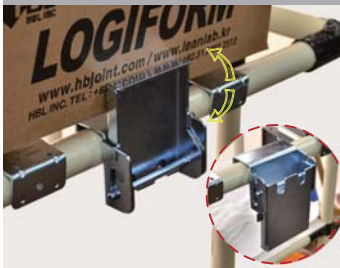
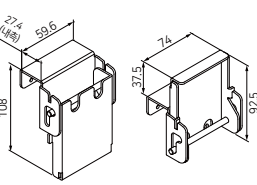
PJ-1401BK PLACON REVERSE BRAKE

1,000pcs/box 12g/pc

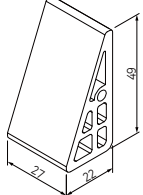
ACCESSORIES

MT-5140A TRACTION ARM-A 500, 견인고리-A500
※ Zinc Plated

2,750g/pc

MT-5141A TRACTION ARM-A 600, 견인고리-A600
※ Zinc Plated

2,980g/pc

MT-5142B TRACTION ARM-B 500, 견인고리-B
※ Zinc Plated

2,180g/pc

MT-5143A/B TRACTION HOOK-A / B
※ Zinc Plated

780g/pc

MT-5149A TRACTION ARM
※ Zinc Plated

2,120g/pc

MT-5149B TRACTION HOOK

1,070g/pc

MT-5144A TRACTION ARM-A 견인고리-A
※ Painted

3,200g/pc

MT-5145A TRACTION HOOK-A 견인고리-A
※ Painted

1,750g/pc

MT-5144B TRACTION ARM-B 견인고리-B
※ Non-Painted, For Welding

3,500g/pc

MT-5145B TRACTION HOOK-B 견인고리-B
※ Non-Painted, For Welding

1,200g/pc

MT-5144C TRACTION ARM-C, 견인고리-C
※ Non-Painted, For Welding

3,500g/pc

MT-5145C TRACTION HOOK-C, 견인고리-C
※ Non-Painted, For Welding

4,600g/pc

ACCESSORIES

ACCESSORIES

MT-5121 STANCHION MOUNT 바닥고정금구

40pcs/box, 178g/pc

MT-5119S SQUARE CAP 사각종발이

50pcs/box, 400g/pc

MT-5119 OVERLAP CAP 중복캡

20pcs/box, 226g/pc

MT-5119W SQUARE CAP 사각종발이
※ Non-Painted, For Welding

35pcs/box, 330g/pc

MT-5100 FORKLIFT HOOK 지게차포크 이탈방지 금구

25pcs/box, 908g/pc

MT-5311 CASTER FIXING HOLDER

120pcs/box, 70g/pc

MT-5148 (4" / 5" / 6") FLOOR LOCK

4" - 1,152g/pc, 30pcs/Box
5" - 1,206g/pc, 20pcs/Box
6" - 2,802g/pc, 8pcs/Box

SV (4" / 5") GN (6")

MT-5151 SLIDE MODULATOR

10pcs/box, 1,268g/pc

MT-5143 GAS SPRING

·10/15/20/30/50kg
·Road : 143mm
·Length : 377mm

100pcs/box, 245g/pc

MT-5211 ZN PLATING ANGLE 아연안글

(3m Standard)

3m/bar, 2,250g/bar

MT-5147 SLIDE RAIL 슬라이드레일

BALL BEARING

SLIDE SIZE : 350~600mm(50mm)간격

654g/pc

ACCESSORIES

FS-0200/ 0250/ 0300/ 0350 FOLDING SHELF BRACKET

접이식 선반대
 ○ WH ○ CR

135
 20

8(in) L:200 / 10(in) L:250
 12(in) L:300 / 14(in) L:350

EX) WH - 8(in) → FS - W 0200
 CR - 8(in) → FS - C 0200

PC-0300

SHARP-EDGE COVER

- PE
- 0.8T ~ 1.5T (THICKNESS)

300m/box, 20g/m

NEW

ACCESSORIES FOR PROFILE

AJ-3143

PROFILE PIPE (ALUMINUM)

25.4
 4.6
 25.4

4m(Standard)

PROFILE PIPE (ALUMINUM)

PC-0200 (BK)

PROTECTION COVER

9
 15.7
 7.4
 20

1Roll=20m
 40m/box, 20m(Standard)

SC-0200 (GR)

SLOT COVER

5.1
 9.2

1Roll=20m
 200m/box, 20m(Standard)

UG-0125A (YL)

URETHANE GUIDE

26.3
 125
 20

700pcs/box, 22.6g/pc

UG-0125B (BL)

URETHANE GUIDE

24
 125
 20

700pcs/box, 19g/pc

UG-0125C (BL)





URETHANE GUIDE





24
 110
 20

800pcs/box, 13.8g/pc

ACCESSORIES

FASTENERS & TOOLS

BOLTS				
ITEM SPECIFICATION	WRENCH BOLT(BK/SV/NI) M6 * 10 / 20 / 25	BOLT M8 * 35 / 40 / 45	BOLT M8 * 50 / 60 / 70	BOLT M10 * 20 / 25
PRODUCT CODE	WB-0610 / 0620 / 0625	BT-0835 / 0840 / 0845	BT-0850 / 0860 / 0870	BT-1020 / 1025

BOLTS NUTS				
ITEM SPECIFICATION	BOLT M12 * 20 / 25	BOLT 1 / 2 * 50	T NUT(BK/SV/NI) M6	NYLON NUT M8 / M10 / M12
PRODUCT CODE	BT-1220 / 1225	BT-1250	NU-0600	NN-0800 / 1000 / 1200

SCREWS						
ITEM SPECIFICATION	ROUND SCREW #8*19/25/32	FLAT SCREW #8*19/25/32	TAPPING SCREW M4*8L	ROUND SCREW M3.5*16L	WIDE SCREW #10*20/25	NUT 1/2
PRODUCT CODE	SR-0819/0825/0832	SF-0819/0825/0832	TS-0408	TS-3516	SW-1020/SW-1025	NU-1200

WRENCH BITS				
ITEM SPECIFICATION	WRENCH BIT 5X70mm / 5X100mm	L-WRENCH BIT 5X165mm	DRIVER BIT 65mm/110mm	ADJUSTER WRENCH -
PRODUCT CODE	TL-4001 / TL-4002	TL-4003	TL-4004/4005	TL-4012

TOOLS				
ITEM SPECIFICATION	RUBBER HAMMER -	DEBURRING CUTTER -	METRIC TAPE MEASURE 5m	ELECTRICITY IMPACT TOOL SET
PRODUCT CODE	TL-4006	TL-4007	TL-4008	TL-4011

NAME PLATES

PRODUCT CODE	HEIGHT	LENGTH	WEIGHT	Q'TY
LH-3010CS	30mm	100	12g	500
LH-3015CS		150	18g	350
LH-3020CS		200	24g	300
LH-3030CS		300	36g	150

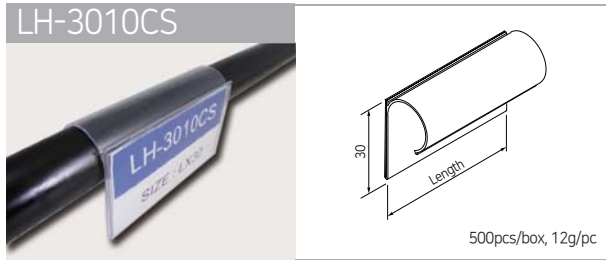

PRODUCT CODE	HEIGHT	LENGTH	WEIGHT	Q'TY
LH-5010CL	55mm	100	22g	400
LH-5015CL		150	33g	200
LH-5020CL		200	44g	200
LH-5030CL		300	66g	100

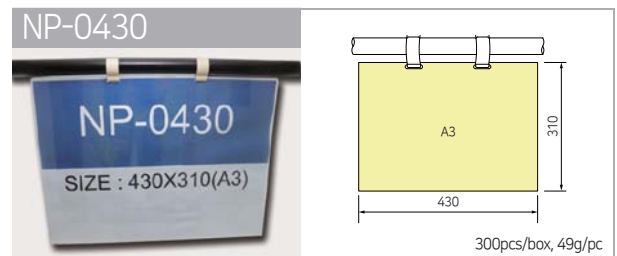
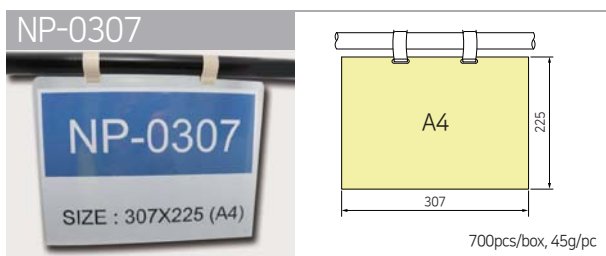
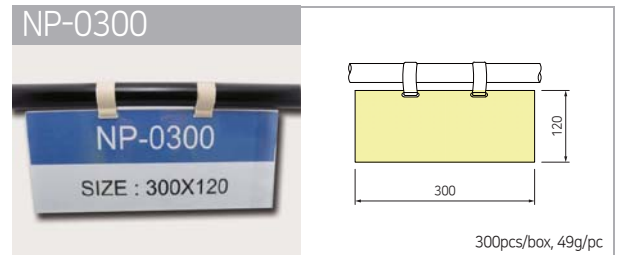
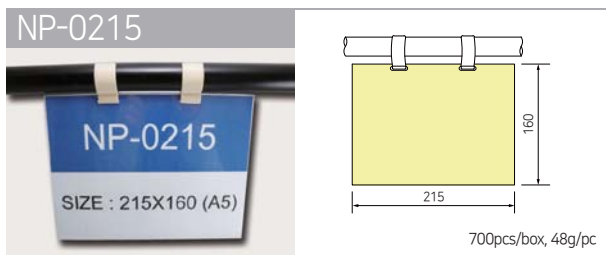
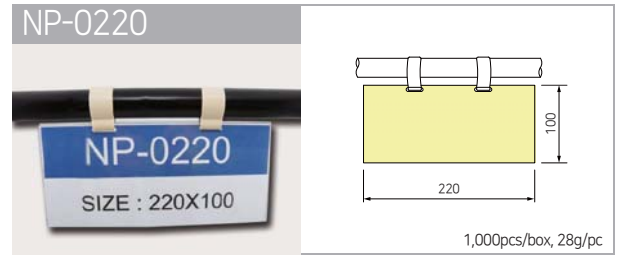
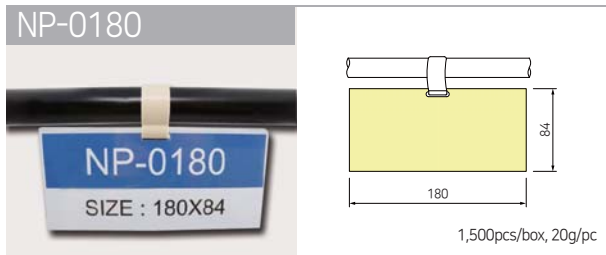
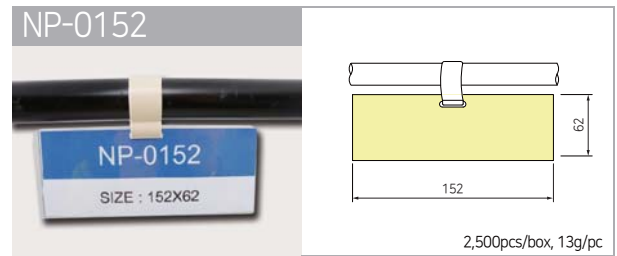
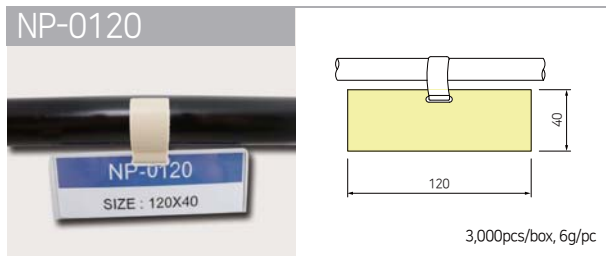
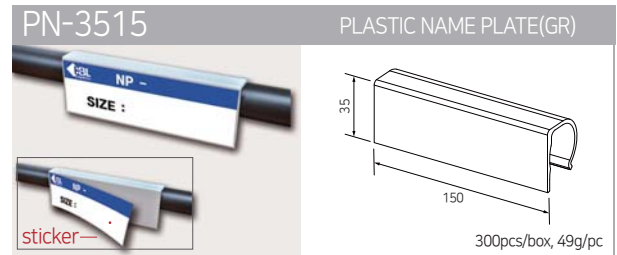
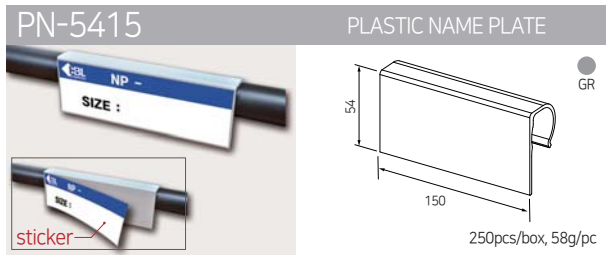
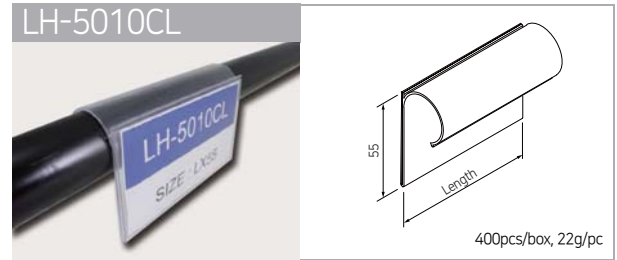





ACCESSORIES

PLASTIC ANGLES & COVERS

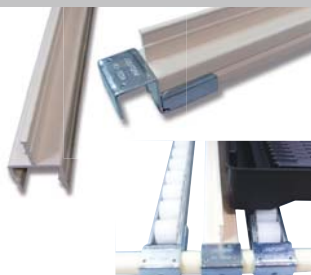
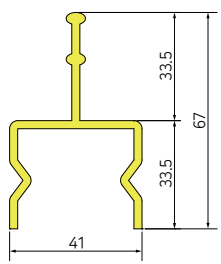
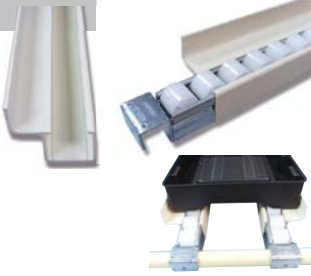
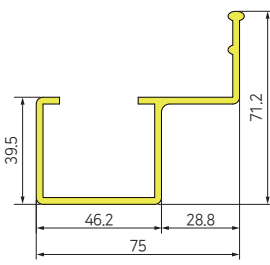
3M Standrad		TYPE	SIZE(3M)	PRODUCT CODE	A	B	C	WEIGHT
<p>① (T-TYPE) ② (L-TYPE) ③ PIPE COVER (IV, GR)</p>	L TYPE		PA-2350T3	30	50	T3	340g/m	
			PA-2890T3	80	90		723g/m	
			PA-2550T4	50	50	586g/m		
			PA-2575T4	50	75	706g/m		
			PA-2510T4	50	100	T4	833g/m	
			PA-2515T4	50	150	1,180g/m		
			PA-2520T4	50	200	1,430g/m		
T TYPE		PA-3510T3	50	100	T3	793g/m		
		PA-31550T4	150	50	T4	1,121g/m		
		PA-3160T4	100	60	T4	1,106g/m		
PIPE FLAT COVER (IV, GR, BK)		PA-4028A (OLD NO : PA-4028T3) IV, GR, BK	-	-	T3	223g/m		
			PA-4028B (IV, GR, BK)	-	-	T2.5	280g/m	
CABLE DUCT		① CD-3000T	-	-	-	158g/m		
		② CD-3000B	-	-	-	282g/m		

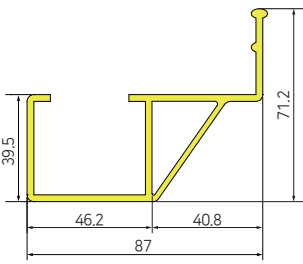
GUIDE RAILS

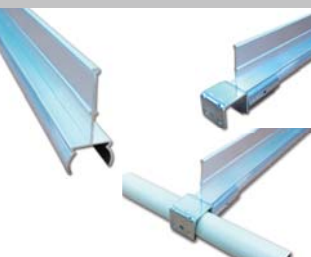
PA-401A	SIZE	TYPE	WEIGHT	LENGTH
		GUIDE RAIL TYPE-A	619g/m	3M(Standard)
		GUIDE RAIL TYPE-B	740g/m	3M(Standard)
PA-412B		GUIDE RAIL TYPE-G	906g/m	3M(Standard)
		GUIDE RAIL TYPE-C	640g/m	3M(Standard)
PA-404D		GUIDE RAIL TYPE-D	824g/m	3M(Standard)
PA-405E		SLIDE GUIDE RAIL ALUMINUM	0.440g/m	4M(Standard)



BOARDS & SHEETS

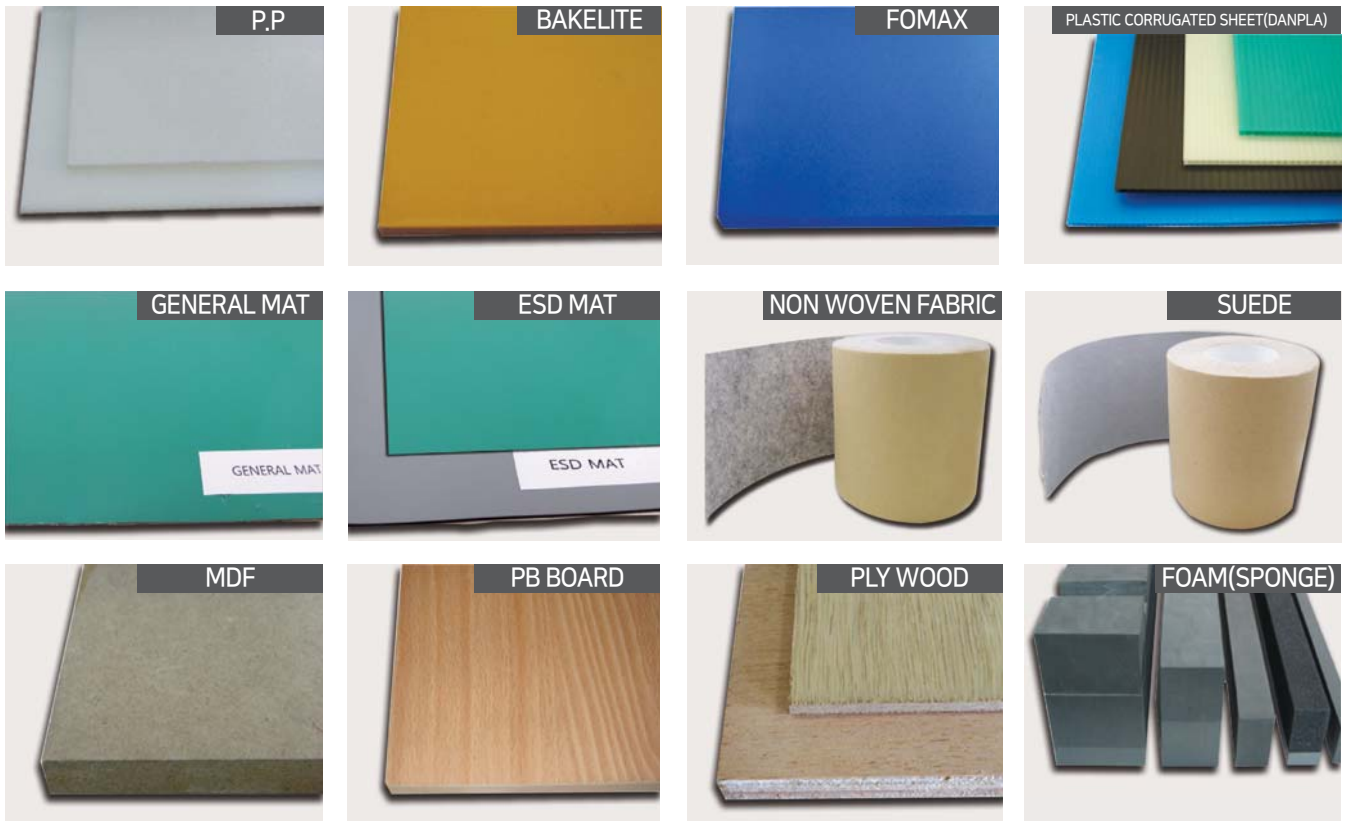

PROTECTION HOSES

CLASSIFICATION				
ITEM	Yarned Thread Hose 편사호스	Transparent Hose 투명호스	Atilon Hose 아티론 호스	Foam Hose (9T/19T) 발포고무 호스
PRODUCT CODE	TH-0001	TH-0002	TH-0003	TH-0005
SPECIFICATION	45m/roll(PVC)	45m/roll(PVC)	4m/pc(ATILON)	2m/pc(RUBBER/SOFT)

※Please contact our sales office with reference to the additional options available.

SPECIFICATIONS

ITEM		SIZE	THICKNESS	COLOR	CHARACTERISTICS(특성)	PRODUCT CODE	
BOARDS (판지)	PLASTIC	PP BOARD (PP)	1200*2400	t5, t7	WHITE	Chemical Resistance Oil Resistance (내유성)	PP-051224 PP-071224
		Poly Vinyl Acetate (PVC)	1200*2400	t5, t7	IVORY GREEN	Smooth Skin (매끈한 외피) Flame-retardant (난연성) Insulation (절연성)	PV-051224 PV-071224
		Plastic Corrugated Sheet (DANPLA)	1500*2000	t5, t9	IVORY, GREEN, BLACK, BLUE	Light weight (경량) Various colors (다양한색상)	DP-051520 DP-091520
		Fomax (포맥스)	1200*2400	t5, t8	BLUE WHITE	Light weight (경량) Easy to produce (가공용이)	FM-051224 FM-081224
		Bakelite (백크라이트)	1000*1000 1000*2000	t5, t8, t12	BROWN, BLACK	High strength (고강도) Fine Insulation (미세한 절연치)	BK-051010 BK-081010
		Poly carbonate (PC)	1200*2400	t3~t5	TRANSPARENT (투명)	Easy to produce (가공용이) High strength (고강도)	PC-031224 PC-051224
		Acryl (아크릴)	1000*2000	t3, t5, t8	TRANSPARENT (투명)		AC-051020 AC-081020
	WOOD	Medium Density Fiberboard (MDF)	1200*2400	t9, t12, t15			MD-091224 MD-121224
		Particle Board (PB)	1200*2400	t15, t30		Coated wood (가구용 코팅 목재)	PB-151224 PB-301224
		Ply Wood (합판)	1200*2400	t9, t12, t15		Easy to produce (가공용이) High strength (고강도)	PW-091224 PW-121224
MATS (매트)	MAT	ESD Mat (정전MAT)	W600*10M	t2	GREEN GRAY	Adhesive / Plain (편제상부 부착용)	EM-060010
			W1000*10M				EM-090010
			W1200*10M				EM-100010 EM-120010
		General Mat (일반MAT)	W1200*30M	GREEN	GM-120030		
PROTECTION OF GOODS (제품보호제)	FABRIC	Non Woven Fabric (부직포)	W1500*100M		GRAY	Anti-scratch (스크래치 방지)	NW-150100
		Suede (스웨이드)	W25*20M				SD-W02520
			W55*20M W100,120,150,200,250				SD-W05520
			W1400*10M				SD-W14010

※Please contact our sales office with reference to the additional options available.



MAT CONVEYORS

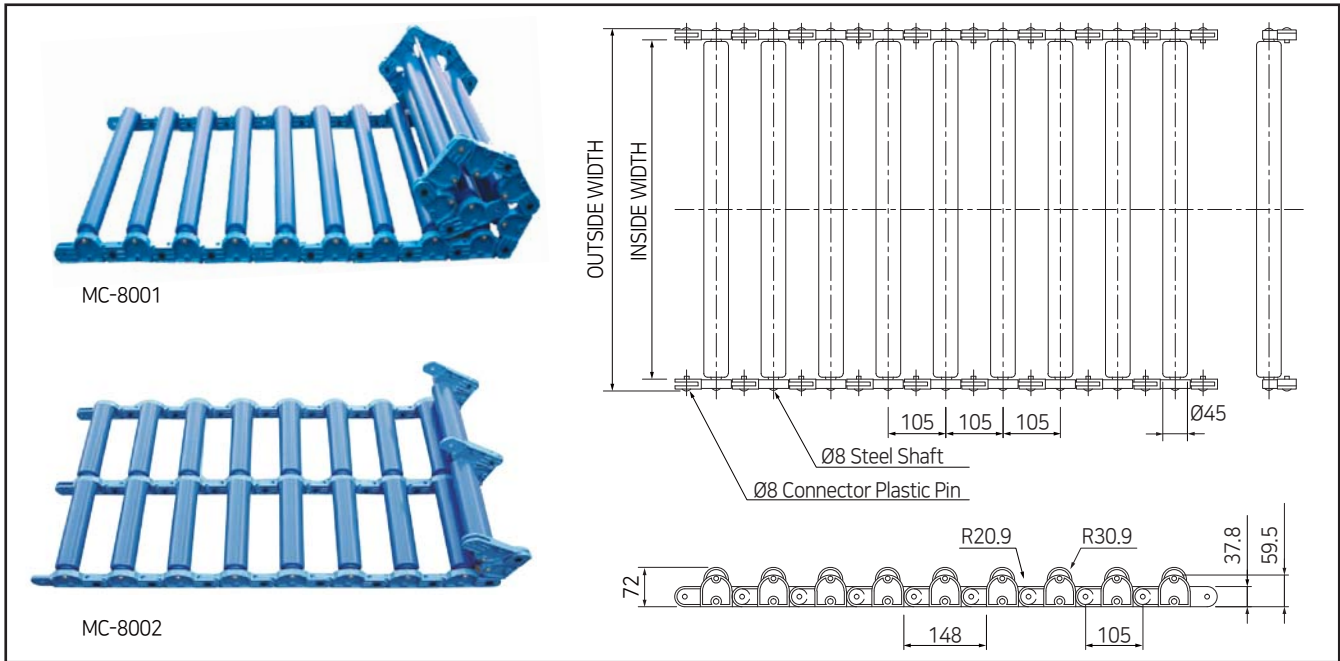

PRODUCT CODE	LOAD (kg/m)	WIDTH(mm)		HEIGHT	PITCH (mm)	WEIGHT (kg/m)
		INSIDE	OUTSIDE(mm)			
MC-8001(single)	200	455	497	75	105	5.4
MC-8002(double)	400	455	497	75	105	6.8

MAT COMAT CONVEYOR SERIES are made with durable industrial ABS resin rollers.

MAT CONVEYOR SERIES are lighter than steel roller conveyors. They are ideally suited for rapid deployment and for temporary handling requirement.

MAT CONVEYOR SERIES are extremely portable due to the light weight and easily folded and unfolded anywhere they are needed.

MAT CONVEYOR SERIES can be produced as per your requirements by specifying the length and width.

매트 컨베어 시리즈는 견고한 ABS엔지니어링 수지로 만들어 졌습니다.

매트 컨베어 시리즈는 철재 컨베어보다 아주 가벼우며, 별도의 장비가 없더라도 긴급한 운반이나 임시 운반에 아주 이상적입니다.

매트 컨베어 시리즈는 휴대하기 좋으며 쉽게 어떠한 장소에서도 연결 및 분리 할 수 있습니다.

매트 컨베어 시리즈는 당신이 원하는 대로 만들 수 있으며, 폭과 길이를 마음대로 조절할 수 있습니다.

